



# Chime Gold

## *Vacuum Tube USB DAC*



Made in USA

---

## ***Copyrights & Trademarks***

© Copyright Hagerman Technology LLC 2006. All rights reserved. No part of this document may be photocopied, reproduced, or translated to another language without the prior written consent.

## ***Disclaimer***

The information contained in this document is subject to change without notice. Hagerman Technology LLC shall not be liable for errors contained herein or for consequential damages in connection with the furnishing, performance, or use of this material.

## ***Warranty***

Hagerman Technology LLC warrants this product free of defects in materials and workmanship for a period of 10 years (90 days for tubes). If you discover a defect, Hagerman Technology LLC will, at its option, repair or replace the product at no charge to you provided you return it during the warranty period, transportation charges prepaid to Hagerman Technology LLC. This warranty does not apply if the product has been damaged by negligence, accident, abuse or misuse or misapplication, has been damaged because it has been improperly connected to other equipment or has been modified without the express written permission of Hagerman Technology LLC. This warranty is limited to the replacement or repair of this product and not to damage to equipment of other manufacturers. Any applicable implied warranties, including warranty of merchantability, are limited in duration to a period of the express warranty as provided herein beginning with the original date of purchase and no warranties, whether express or implied shall apply to the product thereafter. Under no circumstances shall Hagerman Technology LLC be liable for any loss, direct, indirect, incidental, special, or consequential damage arising out of or in connection with the use of this product.

### **Hagerman Technology LLC**

PO Box 26437

Honolulu, HI 96825

808-383-2704 (voice)

808-394-6076 (fax)

[www.hagtech.com](http://www.hagtech.com)

# Description

The Chime Gold is a world-class analog-to-digital converter employing the latest technologies married to vacuum tube amplification for a very clean and open musical reproduction. Input is via USB and optimized for 44.1k Redbook standard. Data is synchronously upsampled to 24-bits at 312.8kHz and re-timed using a super low-jitter flywheel type VCXO-based re-clocker circuit. The actual conversion is done using R2R 24-bit chips (the most expensive you can buy) with phase linear (perfect transient response) output filter / translators. Vacuum tube stages then provide the necessary gain and output buffering.

## Package Contents

- Chime Gold USB DAC
- Power cord
- USB cable

## Specifications

Item	Specification
Input	USB 1.1
Input Data Rate	44.1k
Bandwidth (analog)	10Hz to 100kHz
Gain (analog)	30dB
Distortion	0.03% @1kHz @1Vrms
Output Impedance	1k ohm
Output Voltage	1.2Vrms full scale
SNR (analog)	92dB A-weighted
Size	16" x 12" x 5"
Weight	10.5 lbs.
Input Power	30W
Input Voltage	115V, 230V
Tube Complement	12AX7, 12AU7, 5Y3 (or GZ34)

# Installation

Connecting to your audio system is very easy. Connect the USB cable to your PC, the line level outputs (RCA jacks) to your linestage or integrated amplifier.

There are two front panel switches that change operating modes. The **PHASE** switch changes signal polarity (up is positive). The **FILTER** switch selects between slow rolloff mode (down) and fast rolloff (up). The blue LEDs indicate status of power supplies and signal lock. If the **RX** led is off, then there is no valid 44.1k data signal.

Due to the tube rectified high voltage supply, there is a turn-on delay of about 30 seconds. Proper warm-up takes at least 5 minutes. Best results are after one hour.



## Replacing Tubes

Upgrading the vacuum tubes to quality NOS can have a positive impact on sonics. The first tube (left side) is a 12AX7 type high-gain tube. You can also use a 5751. Second tube is a cathode follower output buffer and is a 12AU7 (5814A, 6067). High voltage rectification is provided by a 5Y3GT, but many other 8-pin types will also work (GZ34, 5AR4, etc.). Always unplug power cord before removing the top cover.

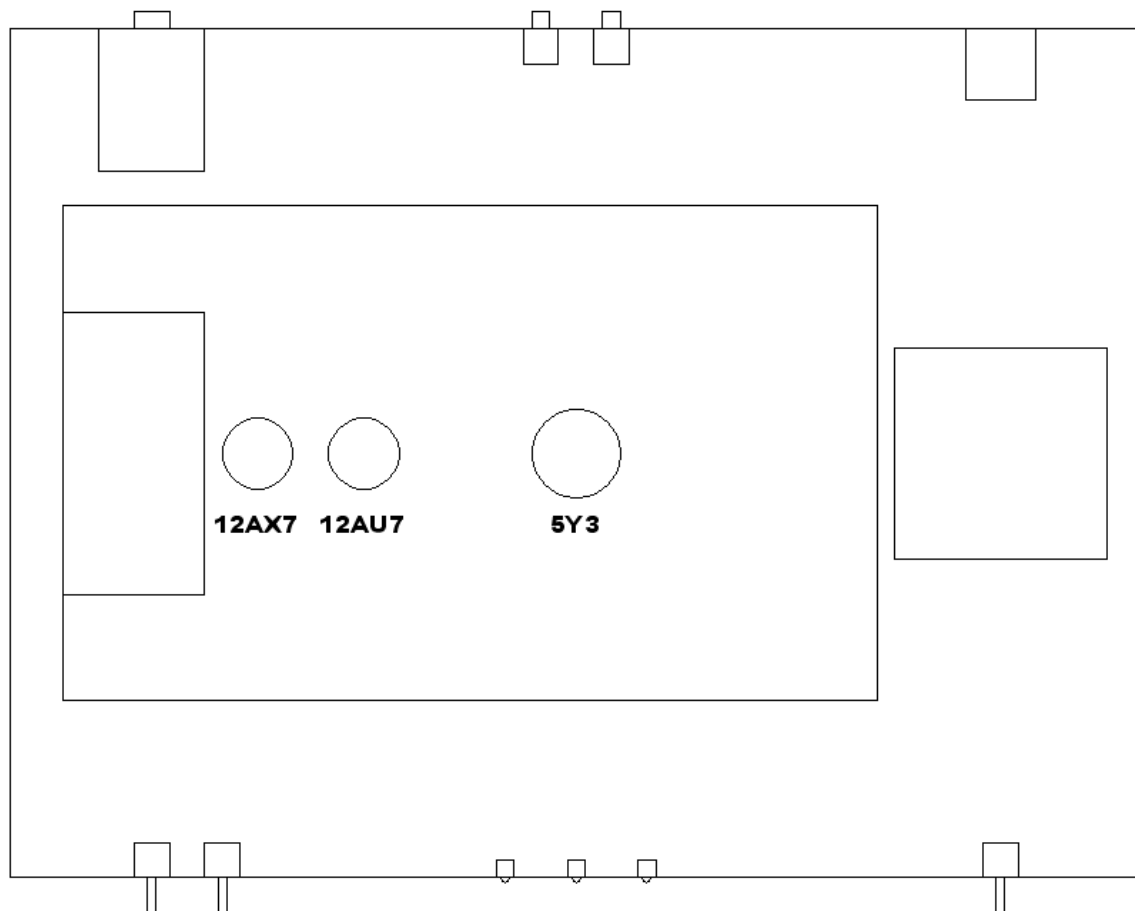

The fuse is located on the circuit board under the transformer wires. It is a 1 amp “slo-blo” 5x20 type.

This document contains proprietary information and except with written permission of Hagerman Technology LLC such information shall not be published, or disclosed to others, or used for any purpose, and the document shall not be copied in whole or in part. Copyright Hagerman Technology LLC 2004. All rights reserved.

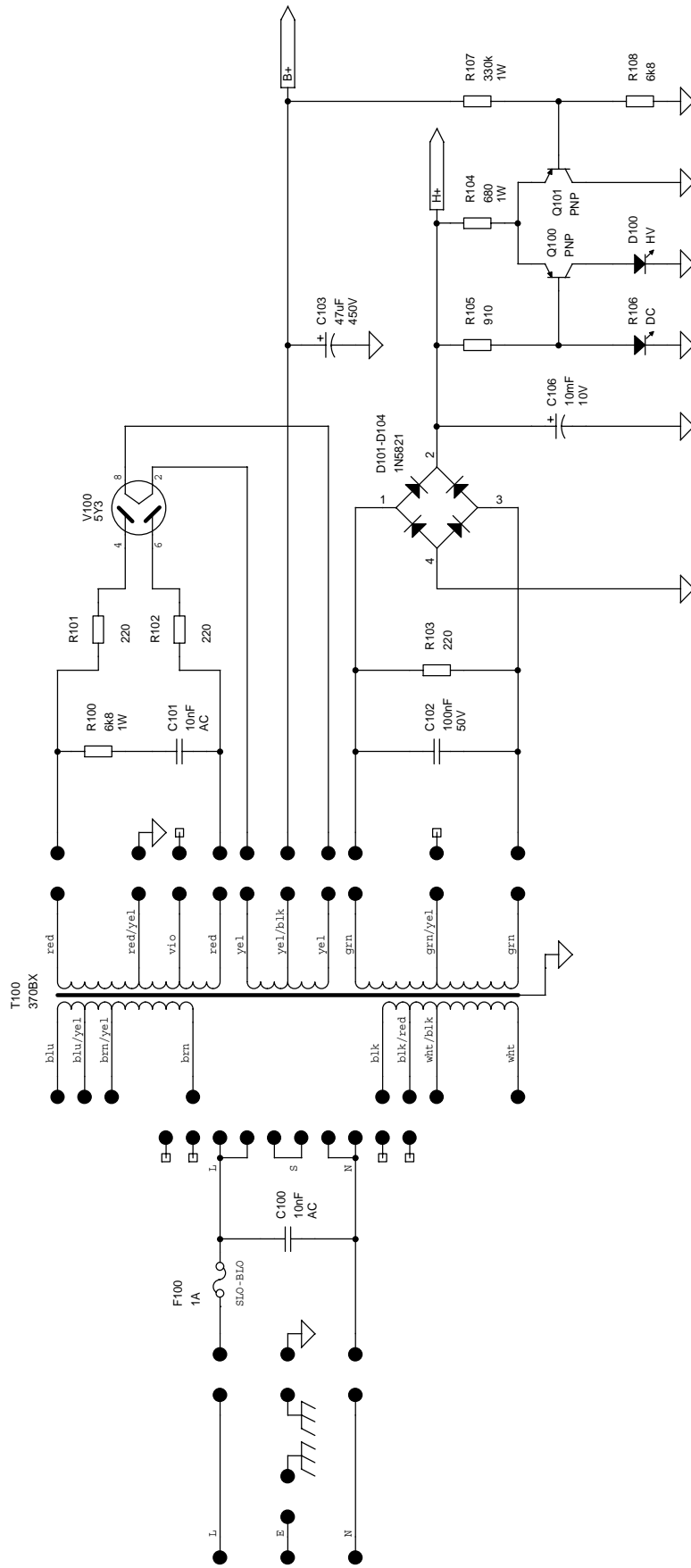

	100V	110V	120V	200V	220V	240V
Blu	NC	NC	L	NC	NC	L
Blu/Yel	NC	L	NC	L	NC	NC
Brn/Yel	L	NC	NC	L	NC	NC
Brn	N	N	S	S	S	S
Blk	NC	NC	L	NC	NC	S
Blk/Red	NC	L	NC	NC	S	NC
Wht/Blk	L	NC	NC	S	NC	NC
Wht	N	N	N	N	N	N

**Hagerman Technology LLC**

P.O. Box 26487  
Honolulu, HI 96825

**Chime Gold: Power Supply**

Title Document Number

Size n/a

Rev A

Date: Wednesday, December 06, 2006 Sheet 1 of 4

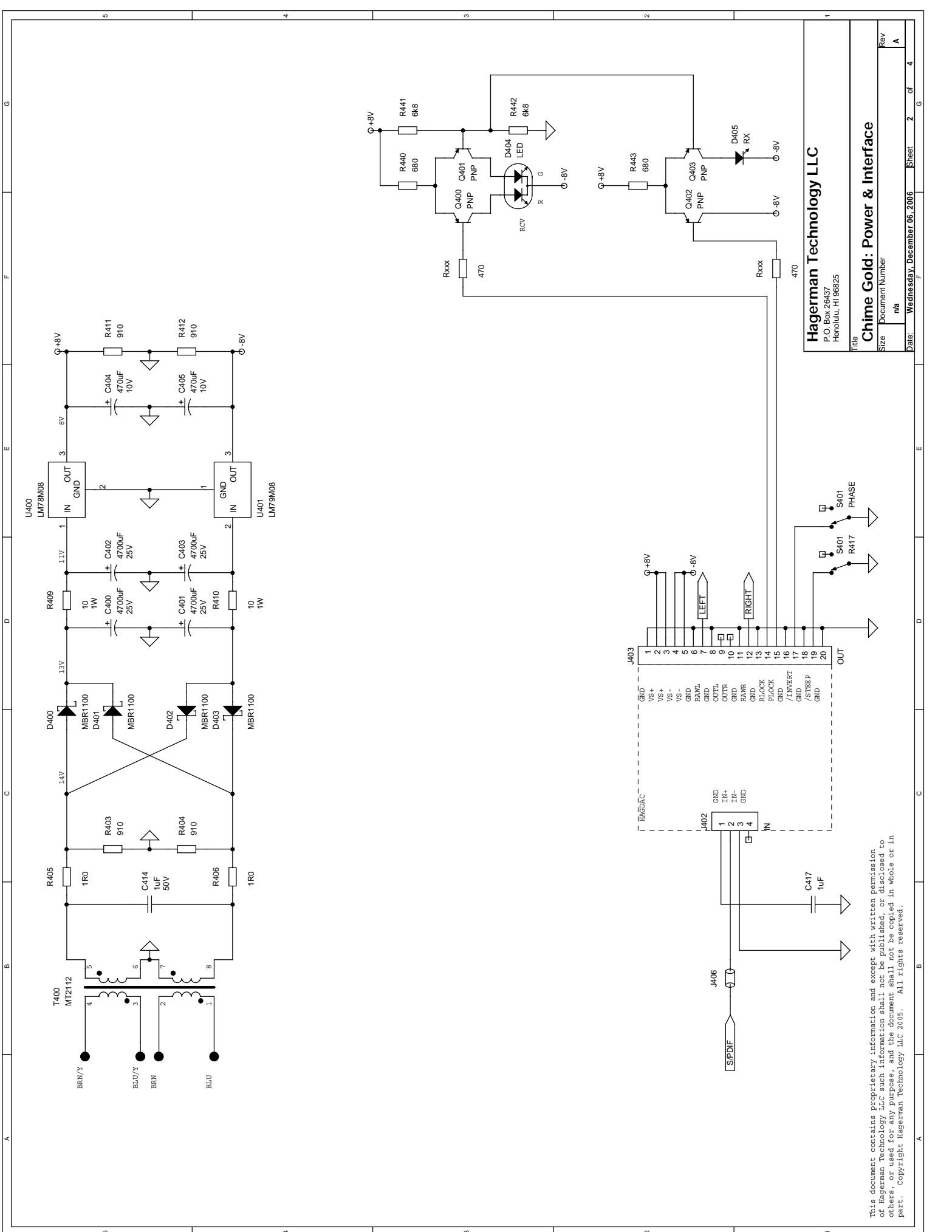

**Hagerman Technology LLC**  
 P.O. Box 26487  
 Honolulu, HI 96825

Title: **Chime Gold: Power & Interface**  
 Size: Document Number  
 n/a  
 Date: Wednesday, December 06, 2006 Sheet 2 of 4

This document contains proprietary information and except with written permission of Hagerman Technology LLC such information shall not be published, or disclosed to others, or used for any purpose, and the document shall not be copied in whole or in part. Copyright Hagerman Technology LLC 2005. All rights reserved.

This document contains proprietary information and except with written permission of Hagerman Technology LLC such information shall not be published, or disclosed to others, or used for any purpose, and the document shall not be copied in whole or in part. Copyright Hagerman Technology LLC 2005. All rights reserved.

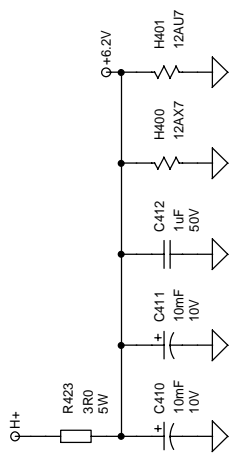
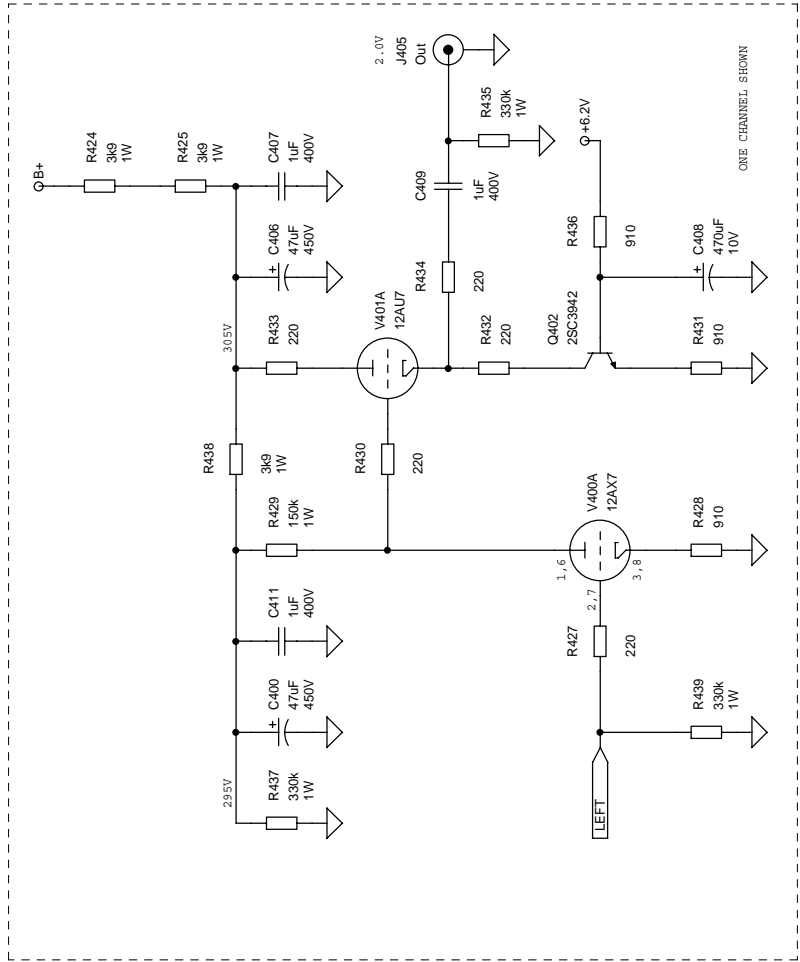

**Hagerman Technology LLC**  
P.O. Box 26487  
Honolulu, HI 96825

**Chime Gold: Amplifier**  
Document Number  
na

Title  
Date: **Wednesday, December 06, 2006** Sheet 3 of 4

Rev  
A



This document contains proprietary information and except with written permission of Hagerman Technology LLC such information shall not be published, or disclosed to others, or used for any purpose, and the document shall not be copied in whole or in part. Copyright Hagerman Technology LLC 2005. All rights reserved.

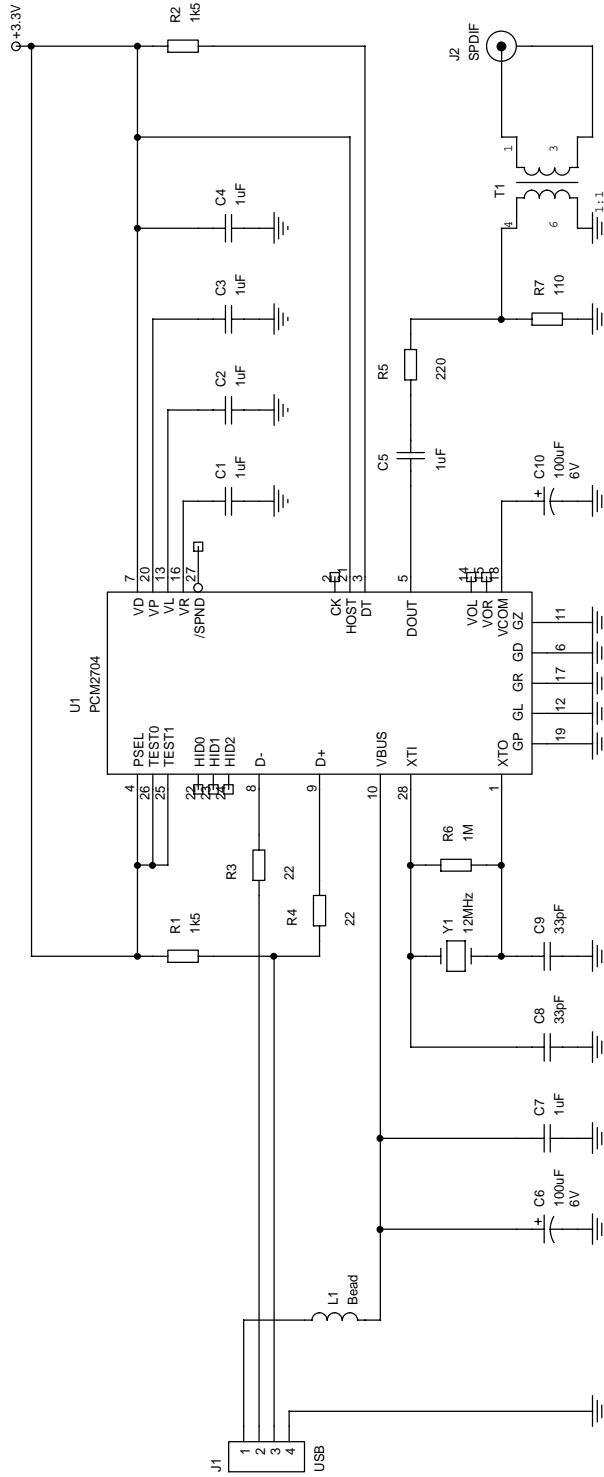

**Hagerman Technology LLC**

P.O. Box 26487  
Hendriks, RI 06025

**Chime Gold: USB Input**

Title	
Size	Document Number
Rev	na
Date	Wednesday, December 06, 2006
Sheet	4 of 4